

EXPERIMENTALLY USE OF GLYCEROL AS A BIOFUEL IN OXY-COMBUSTION THERMAL PROCESS

Lucian Paunescu¹, Gheorghe Surugiu² and Eniko Volceanov^{3,4}

¹ Cosfel Actual SRL Bucharest, Romania, lucianpaunescu16@gmail.com

² State Inspection for the Control of Boilers, Pressure Recipients and Lifting Installations Bucharest, Romania, gsurugiu2000@yahoo.com

³ Metallurgical Research Institute SA Bucharest, Romania, enikovolceanov@gmail.com

⁴ University POLITEHNICA of Bucharest, Faculty of Material Science and Engineering, Bucharest, Romania, enikovolceanov@gmail.com

ABSTRACT: The renewable energy that also includes bioenergy represents the viable alternative of improving the environment quality and at the same time, protecting the natural fossil fuel reserves globally diminished in the last period. Having biological origins, the burning of biofuels for energy purposes is a non-conventional process accepted on the global scale as a solution to replace polluting fossil fuels. The work aims to test the conditions of using glycerol together with ethanol as biofuels in an original oxy-fuel combustion process. All oxy-liquid biofuel burners designed and experimentally tested in the world are intended for internal combustion engines, while the burner presented in this paper is designed for heating boilers and furnaces, the difference in the constructive and functional principle determining the paper originality. The experiment carried out on the burners testing stand in the Metallurgical Research Institute of Bucharest allowed establishing the optimal characteristics of the process for the nominal heat power of 60 kW under the conditions of obtaining a stable flame, with high temperature (1781-1846 °C) and moderate emissions of carbon dioxide (below 0.13 vol. %) and nitrogen oxides (152-210 mg/m³N).

KEYWORDS: biofuel, glycerol, ethanol, oxygen, stable flame, burner.

1. INTRODUCTION

Fossil fuels (coal, oil, hydrocarbons) used intensively in the world for over 100 years have had a harmful influence on the quality of the environment through the emission of greenhouse gases (mainly carbon dioxide CO₂), but these consequences have only been identified in the last decades of the 20th century. According to [1], over 25 % of the CO₂ emitted by fossil fuels is absorbed by the seas and oceans of the planet, changing their acidity (by approximately 30 % in the last 150 years), disturbing underwater life and implicitly, fishing, tourism, and economy. Also, the climate change is causing severe weather events as well as rising ocean levels due to the glaciers melting. On the other hand, greenhouse gas emissions generate hazardous atmospheric pollutants including sulphur dioxide (SO₂), nitrogen oxides (NO_x), carbon monoxide (CO), etc. dangerous for health as well as acid rain. Also, wastewater can result, which due to the possible content of arsenic, lead, chlorine, and mercury becomes toxic. In the last 30-40 years, several measures for reducing the severe consequences of fossil fuel consumption have been conceived: increasing the social cost of carbon, encouraging clean electricity sources and non-polluting alternative fuels.

In the period 2019-2024, the renewable energy should increase by 50 %, of which the increase in solar

energy would reach 30 %, according to the forecast of the International Energy Agency (IEA) [2]. Also, the use of wind energy is estimated to reach 25 %, while the use of bioenergy will increase by 4 % compared to 2019.

The use of energy provided by biofuels has become one of the major concerns at the global level under the conditions where the emission of greenhouse gases (GHG) is an important problem for the protection of the earth's atmosphere and also under the conditions of the reduction of traditional fossil fuel resources.

Biofuels are generally obtained from processing the biological materials, mainly from plants, animals, waste and microorganisms, which constitute biomass. The main solid biofuels are: firewood, charcoal and fibrous materials. Methane and other gases formed from geological and biological processes are mainly gaseous biofuels that can be obtained by fermenting domestic animal waste and by pyrolysis or gasification of agricultural waste or wood [3]. The numerous types of liquid biofuels such as methanol, ethanol, organic oils, and methyl esters are generally assigned as biodiesel [4].

According to [5], biofuels can be grouped into two age categories. Sugarcane-ethanol, corn-ethanol, starch-based biodiesel, and pure vegetable oils are first generation biofuels. The most known and important biofuels in this category are vegetable oils,

bio-alcohols, biodiesel, biogas, and solid biofuels [6]. The second generation of biofuels, also known as "advanced biofuels", consists of sources with very difficult production compared to the first generation of biofuels. The feedstock consists of wood, agricultural residues, organic waste, food waste, specific biomass crops together with cellulose, hemicellulose or lignin. This biofuel can be combined with petroleum-based fuels for burning in existing internal combustion engines. Biofuels of the second generation are not yet manufactured for trade. However, research activities in this field are known in North America, Europe and several other developing countries (Brazil, China, India, and Thailand) [7-15]. A third generation of biofuels consisting of the use of algae biomass comparable to conventional lignocellulosic biomass was also accepted. Algae can produce more than 30 times more energy compared to land crops such as soy [5].

Biofuels, especially for burning in internal combustion engines in the field of transportation, are considered a viable alternative for reducing GHG emissions, because biofuels are obtained through processes characterized by very low emissions and the combustion of this fuel type is ecological. Several programs on the production and using biofuels have been implemented in the last years in the United States and the European Union aimed at reducing GHG emissions and saving fossil fuel. However, recent estimates show that only 1 % of the energy used in the world comes from the biofuels application, there are opportunities for the significant improvement of the biofuel/fossil fuel ratio through the development and finishing the research in this field [16].

The current paper aims to create an oxy-biofuel burner for thermal energy purposes using glycerol as biofuel. The originality of the work is the type and destination of the energy equipment, unlike all burners operating with biofuels previously experienced according to the literature for internal combustion engines.

2. METHODS AND MATERIALS

2.1 Methods

The glycerol used in this experiment as a biofuel with high water content has low volatility with vapour pressure of $106 \cdot 10^{-6}$ hPa at 25 °C [17]. Theoretically, to obtain a stable flame, the concentration of glycerol in water should be reduced. For low concentrations up to 60 wt. % the flame is unstable being removed from the nozzle. By comparison, ethanol, a biofuel with high volatility, forms a stable flame even at a much lower concentration in water. The difference

between the two biofuels is that glycerol is less volatile than water, while ethanol is more volatile than its. In the first case, water is preferentially vaporized and in the second case, ethanol is preferentially vaporized. Thus, the operation stability of the flame of a fuel with lower volatility compared to that of water is difficult to achieve, when the weight proportion of spraying water of the liquid fuel is high. According to the literature [18], improving the flame stability of an aqueous solution of glycerol can be achieved by adding low proportions of ethanol (or butanol). Thus, satisfactory results were obtained for a concentration of 30 wt. % glycerol in water and the addition of 10 wt. % ethanol or 8.3 wt. % butanol.

Achieving the flame stability leads to the formation of a high-temperature zone in the vicinity of the burner nozzle due to the preponderant vaporization of ethanol with high-volatility from the biofuel composition, which generates heat to vaporize the fuel in its entirety.

The constructive scheme of the burner was adopted considering the need for stability in the operation of its flame. Thus, the possibility of recirculating the fuel and oxygen jets on the metal surface of the nozzle (perpendicular to the direction of flame propagation) was created, forming vortices in this area according to the principle of operation of swirl burners [19]. The constructive and functional principle is shown in Figure 1.

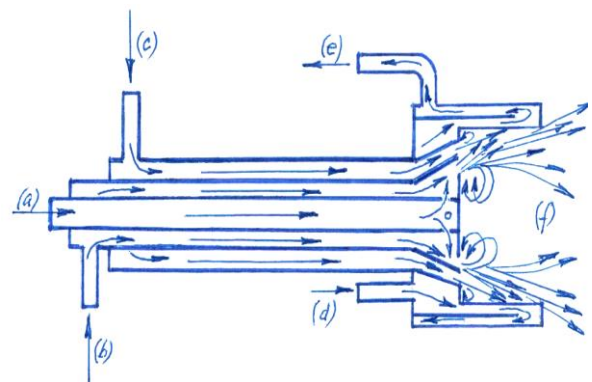
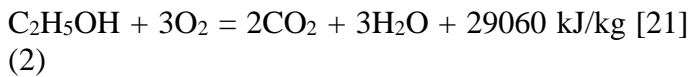
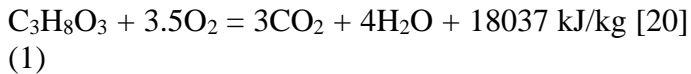

Figure 1. Constructive and functional scheme of the oxy-biofuel burner
a – glycerol + ethanol; b – spraying water; c – oxygen; d – cooling water inlet; e – cooling water outlet; f – oxy-biofuel flame.

The method adopted by the authors assumed the use of a mixture of biofuels composed of glycerol ($C_3H_8O_3$) (concentration of 30 wt. % in water) and ethanol (C_2H_5OH) (between 9-12 wt. %), the combustion process being performed by the introduction of technical oxygen in the contact area with the mixture of biofuels sprayed with water. The two biofuels react exothermically with oxygen according to reactions (1) and (2).



2.2 Materials

As mentioned above, the products used as feedstock in the oxy-combustion process were: glycerol, ethanol, technical oxygen, and water as a spraying agent.

Glycerol is a polyol compound. It is usually obtained from plant and animal sources being located in triglycerides. Processes of hydrolysis, saponification or transesterification of triglycerides [22] produce glycerol as a by-product. Glycerol made from triglycerides is widely used in the world at a low price of 2-5 US cents/kg [23].

Ethanol belongs to the class of alcohols, being an important product of the chemical industry (at the current price of 26 US cents/kg) and is used as a solvent in synthesis processes as well as an additive in automobile diesel. It is produced by fermentation of carbohydrates (sugarcane and corn crops) or hydration of ethylene [24].

The two biofuels mentioned above were purchased from the market and bottled. The burner was supplied with these liquid fuels using a pump through a flexible connection. The spraying water supply was carried out through a flexible connection from the industrial water source.

The technical oxygen can be industrially generated by several methods. The common technique is the separation of air using a cryogenic distillation process or a vacuum swing adsorption process. Since the experiment took place in a hall in Metallurgical Research Institute Bucharest, the technical oxygen supply was provided from the internal general oxygen pipe through a flexible connection.

3. RESULTS AND DISCUSSION

3.1 Results

The burners testing stand (shown in Figure 2) used for the attempt of the oxy-biofuel burner is a horizontal cylindrical enclosure refractory lined and cooled with water, having a length of 2.5 m and the inner diameter of 500 mm. Numerous viewing holes provided on the cylindrical wall of the stand allow visualization of the flame propagation and measurement of its temperature, chemical composition, and dimensions. At the end opposite to the position of the burner, a hot gas-water heat exchanger was mounted to take over

the heat contained in the residual gases. The analysis of the chemical composition of waste gases was carried out with the Testo 350 analyzer and the flame temperature was identified with the Pyrovar type radiation pyrometer.

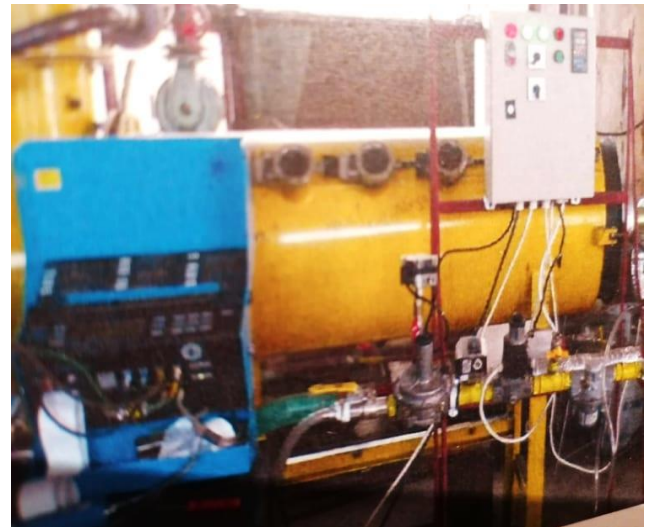

Figure 2. Image of the burners testing stand

The nominal design data of the oxy-biofuel burner were determined by the authors and indicated in Table 1.

Table 1. Nominal design data of the oxy-biofuel burner

Date	Unit	Value
Burner heat power	kW	60
Glycerol flow rate	kg/h	9.95
Ethanol flow rate	kg/h	1.23
Glycerol-ethanol mixture pressure	bar	0.4
Spraying water flow rate	kg/h	78.3
Spraying water pressure	bar	1.6
Oxygen flow rate	m ³ N/h	27.2
Oxygen pressure	mbar	185
Biofuel mixture rate in radial orifices	m/s	170
Biofuel spray rate in the annular section	m/s	200
Oxygen rate in the annular section	m/s	210
Waste gas rate at the exit from the burner	m/s	130
Cooling water flow rate	m ³ /h	1.9
Cooling water rate	m/s	1.4

Preliminary tests carried out by the authors on the experimental burner showed that the optimal flame stability was obtained in the variant of using 89 wt. % glycerol and 11 wt. % ethanol. Taking into account the values of the oxidation reaction heat of glycerol (18037 kJ/kg) and ethanol (28060 kJ/kg), the weight proportions of the two biofuels experimentally determined and the adopted nominal heat power of 60 kW, the hourly flow rates could be calculated for the mixture components: 9.95 kg/h (glycerol) and 1.23

kg/h (ethanol). The supply pressure with the liquid fuel mixture was 0.4 bar, while the supply pressure with spraying water (78.3 kg/h) was 1.6 bar. The spraying water/biofuel mixture weight ratio was adopted at the value of 7. The total amount of oxygen for biofuel mixture combustion was of minimum 38.515 kg/h, i.e. 26.97 m³N/h. By adopting a low oxygen excess of 1.01 resulted that the hourly oxygen flow rate is 27.2 m³N/h at the supply pressure of 185 mbar. The following rate values were adopted: 170 m/s for biofuel mixture in radial orifices, 200 m/s for biofuel spray in the annular section, 210 m/s for

oxygen in the annular section and 130 m/s for waste gas at the exit from the burner.

The functional parameters of the 60 kW oxy-biofuel burner were determined for five thermal regimes in which the hourly flow of biofuel mixture was varied between 6.90-11.18 kg/h, the hourly flow of spraying water had values between 48.3-78.3 kg/h, and the hourly flow of oxygen was in the range 16.8-27.2 m³N/h. Table 2 presents the results of the experimental test.

Table 2. Functional parameters of the 60 kW oxy-biofuel burner

Parameter	Thermal regime				
	No.1	No.2	No.3	No.4	No.5
Biofuel mixture flow rate (kg/h)	11.18	10.30	9.00	7.80	6.90
Spraying water flow rate (kg/h)	78.3	72.1	63.0	54.6	48.3
Oxygen flow rate (m ³ N/h)	27.2	25.1	21.9	19.0	16.8
Waste gas oxide composition					
- O ₂ (vol. %)	0.03	0.05	-	0.10	0.06
- NO (mg/m ³ N)	208	199	192	175	152
- NO ₂ (mg/m ³ N)	210	201	195	179	156
- CO ₂ (vol. %)	0.13	0.10	0.11	0.08	0.06
- CO (vol. %)	-	-	-	-	-
Flame temperature (°C)	1846	1839	1823	1805	1781
Flame length (mm)	590	570	540	510	470

The data analysis in Table 2 show that the combustion with technical oxygen of the biofuel mixture leads to ecological emissions of waste gas. Despite the absence of combustion air and the exclusive use of oxygen, nitrogen oxides (NO and NO₂) are still identified in the waste gas composition, but in small quantities. As mentioned above, with the decrease of the flame temperature from 1846 to 1781 °C, the content of nitrogen oxides is reduced from 208 to 152 mg/m³N (NO) and respectively, from 210 to 156 mg/m³N (NO₂). The concentration of CO₂ in waste gas is very low (below 0.13 vol. %), while the concentration of CO is completely non-existent. The flame length of the burner is 590 mm and it decreases with the decrease in the level of the thermal regime up to 470 mm. The appearance of the flame for the nominal thermal regime is shown in Figure 3.

As mentioned above, the flame is stable, is developing with high rate and is very bright.



Figure 3. Image of the flame appearance corresponding to the nominal thermal regime

3.2 Discussion

In the case of burning glycerol as a biofuel used singularly, according to data from the literature, a pronounced tendency to instability in the flame's operation was observed. The addition to the glycerol composition of some biofuels (butanol, ethanol, methanol) whose combustion is characterized by functional stability, allows obtaining the stabilization of the flame of the mixture despite the relatively low proportions of the additions. This solution was basically adopted by the authors, the tests performed with the designed burner experimentally determining

the optimal weight ratio between glycerol and ethanol.

An important role in improving flame stability is played by the waste gas recirculation technique in the nozzle head area, a method known and applied much earlier in the case of swirl burners operating with gaseous fossil fuels (mainly natural gas).

The use of technical oxygen as an oxygen supplier in the combustion process, replacing the atmospheric air or the air partially enriched in oxygen, allows the elimination or reduction of the inert gas (nitrogen from the air), which does not participate in combustion process, producing only the waste gas cooling. On the other hand, the nitrogen present in the gas composition facilitates the formation of polluting nitrogen oxides (NO_x). By using only oxygen, this ecological disadvantage is largely eliminated, leaving the conditions for the NO_x formation through the absorption of nitrogen from the atmosphere mainly due to the high temperature of the combustion process. The presence of spraying water in the combustion zone does not have the role of cooling the flame, but on the contrary, the temperature of the flame is increased due to the exothermic reaction of water vaporization.

4. CONCLUSION

The objective of the work was the conception, realization and testing of an oxy-biofuel burner intended for convective and radiant heating processes of boilers and furnaces. According to the literature, liquid biofuels regardless of the type of material (methanol, butanol, glycerol, vegetable oil, ethanol, etc.) are intended for combustion processes in internal combustion engines. The main degree of originality of the work comes from the fact that the oxy-biofuel burner designed by the authors is intended for heating boilers and furnaces, involving relatively different solutions imposed by the peculiarities of the thermal process. The main challenge of the research was the need to ensure the stability of the flame during operation, under the conditions of adopting glycerol as biofuel, the major difficulty coming from the unstable burning peculiarity of glycerol when it is used singularly. One of the methods known in principle is the combination of glycerol with other types of liquid biofuels (butanol, ethanol, methanol) whose stability in individual combustion is satisfactory. Ethanol was adopted in a weight ratio between 9-12 % and preliminary tests led to the choice of the proportion of 11 % in the mixture with glycerol. Other original elements of the paper were the technique of spraying the liquid mixture with water jets distributed radially at a high rate, providing a fine rain of fuel for the intimate contact with oxygen

jets as well as the recirculation method of waste gas in the area of the nozzle head that favours the flame stability by creating turbulence in this area. The experimental results showed that the operation of the oxy-biofuel burner using glycerol and ethanol is stable and safe in the range of 6.90-11.18 kg biofuel/h. The flame temperature was between 1781-1846 °C with lengths between 470-590 mm. The analysis of waste gas taken from the flame indicated extremely low concentrations of CO₂ (below 0.13 vol. %), lack of CO in the gas composition and low concentrations of NO (between 152-208 mg/m³N) and NO₂ (between 156-210 mg/m³N). The identification of NO and NO₂ concentrations under the conditions of combustion with only oxygen is due to the very high temperature of the flame.

The paper confirmed the viability of technical solutions adopted by authors and that the combustion of glycerol together with ethanol using technical oxygen is an option for heating processes (at high temperature) in boilers and furnaces substituting the fossil fuels.

5. REFERENCES

1. Bertrand, S., *Fact sheet/Climate, environmental, and health impacts of fossil fuels*, Environmental and Energy Study Institute, Washington DC, the United State, (2021).
2. *World Energy Outlook*. Report Extract Data, The International Energy Agency (IEA), Paris, France, (2019).
3. Szwaja, S., Kovacs, V.B., Bereczky, A., Penninger, A., Sewage sludge producer gas enriched with methane as a fuel to a spark ignited engine, *Fuel Processing Technology*, Vol. 110, pp. 160-166, (2013).
<https://doi.org/10.1016/j.fuproc.2012.12.008>
4. Chiamonti, D., Oasmaa, A., Solantausta, Y., Power generation using fast pyrolysis liquids from biomass, *Renewable and Sustainable Energy Reviews*, Vol. 11, No. 6, pp. 1056-1086, (2007).
<https://doi.org/10.1016/j.rser.2005.07.008>
5. Datta, A., Hossain, A., Roy, S., An overview on biofuels and their advantages and disadvantages, *Asian Journal of Chemistry*, Vol. 31, No. 8, pp. 1851-1858, (2019).
<https://doi.org/10.14233/ajchem.2019.22098>
6. Jeswani, H.K., Chilvers, A., Azapagic, A., Environmental sustainability of biofuels: a review, *Proceedings of the Royal Society: Mathematical, Physical and Engineering Sciences*, (2020).
<https://doi.org/10.1092/rspa.2020.03.59>
7. Micić, V., Jotanović, M., Bioethanol as fuel for internal combustion engines, *Zastita Materijala*,

- Vol. 56, No. 4, pp. 403-408, (2015). <https://doi.org/10.5937/ZasMat1504403M>
8. Qian, Y., Sun, S., Ju, D., Shan, X., Lu, X., Review of the state-of-the-art of biogas combustion mechanisms and applications in internal combustion engines, *Renewable and Sustainable Energy Reviews*, Vol. 69, pp. 50-58, (2017). <https://doi.org/10.1016/j.rser.2016.11.059>
 9. Likhanov, V.A., Lopatin, O.P., Method of calculation the working process of the engine when working on methanol, *IOP Conf. Series: Materials Science and Engineering*, Vol. 919, pp. 062008 1-6, (2020). <https://doi.org/10.1088/1757-899X/919/6/062008>
 10. Hönig, V., Kotek, M., Marik, J., Use of butanol as a fuel for internal combustion engines, *Agronomy Research*, Vol. 12, No. 2, pp. 333-340, (2014).
 11. Szybist, J.P., Song, J., Alam, M., Boehman, A.L., Biodiesel combustion, emissions and emission control, *Fuel Processing Technology*, Vol. 88, No. 7, pp. 679-691, (2007). <https://doi.org/10.1016/j.fuproc.2006.12.008>
 12. Coronado, C.R., Carvalho Jr., J.A., Quispe, C.A., Sotomonte, C.R., Ecological efficiency in glycerol combustion, *Applied Thermal Engineering*, Vol. 63, pp. 97-104, (2014). <https://doi.org/10.1016/j.applthermaleng.2013.11.004>
 13. Mohanna, H., *Combustion of pulverized biomass: impact of fuel preparation and flow conditions*, PhD Thesis at Normandie Université, Rouen, France, (2020). <https://tel.archives-ouvertes.fr/tel-03272429/document>
 14. Elfasakhany, A., Investigation of biomass powder as a direct solid biofuel in combustion engines: Modelling assessment and comparisons, *Aim Shams Engineering Journal*, Vol. 12, No. 3, pp. 2991-2998, (2021). <https://doi.org/10.1016/j.asej.2021.03.005>
 15. Capuano, D., Costa, M., Di Fraia, S., Massarotti, N., Vanoli, L., Direct use of waste vegetable oil in internal combustion engines, *Renewable and Sustainable Energy Reviews*, Vol. 69, pp. 759-770, (2017). <https://doi.org/j.rser.2016.11.016>
 16. Ramos, J.L., Valdivia, M., Garcia-Lorente, F., Segura, A., Benefits and perspectives on the use of biofuels, *Microbial Biotechnology*, Vol. 9, No. 4, pp. 435-440, (2016). <https://doi.org/10.1111/1751-7915.12356>
 17. Wernke, M.J., Glycerol in *Encyclopedia of Toxicology*, 3rd edition, Elsevier Online Publishing, Wexler, P. (ed.), (2014). <https://www.elsevier.com/books/encyclopedia-of-toxicology/wexler/978-0-12-386454-3>
 18. Yi, F., Axelbaum, R.L., Oxy-combustion of low-volatility liquid fuel with high water content, *Energy & Fuels*, Vol. 29, No. 2, pp. 1137-1142, (2015). <https://doi.org/10.1021/ef5019516>
 19. Mihaescu, L., Cristea, E.D., Panoiu, N., *Arzatoare turbionare: Teorie, constructie, utilizare*, Editura Tehnica, Bucuresti, (1986).
 20. *CHRIS Hazardous Chemical Data*, US Government Printing Office, Department of Transportation, Vol. 2, p. 5, Washington DC, (1984).
 21. Haynes, W.M., *CRC Handbook of Chemistry and Physics*, 95th edition, CRC Press LLC, Boca Raton, Florida, the United States, (2014-2015), pp. 5-68.
 22. Rubianto, I., Santosa, S., Sudarminto, H.P., Udjiana, S.S., Glycerol from waste frying oil as sustainable fuel, *IOP Conf. Series: Materials Science and Engineering*, Vol. 732, *The 1st Annual Technology, Applied Science, and Engineering Conference*, Vol. 732, East Java, Indonesia, August 29-30, (2019).
 23. Pei, S.K., Mohamed, K.A., Dand, A.W., Mohd, W., Conversion of crude and pure glycerol into derivatives: A feasibility evaluation, *Renewable and Sustainable Energy Reviews*, Vol. 63, pp. 533-555, (2016). <https://doi.org/10.1016/j.rser.2016.05.054>
 24. *Ethanol-chemical compound*, Encyclopaedia Britannica, August, (2022). <https://www.britannica.com/science/ethanol>